



GAI-TRONICS®
A HUBBELL COMPANY

Model 370-901 SP2 to Page/Party® Bridge

TABLE OF CONTENTS

<i>Confidentiality Notice</i>	<i>1</i>
<i>General Information</i>	<i>1</i>
Features	1
Option	1
<i>Installation</i>	<i>2</i>
Important Safety Instructions	2
Open the Enclosure	2
Mount the Enclosure	3
Field Terminations	3
Earth Ground.....	3
Ethernet—TB1	4
Page/Party® 33-Ohm Audio Connections—P2.....	5
60029 Series Page/Party® System Cable.....	5
Channel Isolation Inputs—P3	6
Contact Outputs—P4	6
Mute Connection—P5	7
Power—P1	7
Close the Enclosure	7
<i>Configuration</i>	<i>7</i>
Interface Configuration	9
Channel Configuration	10
GUDA Status	11
Interface Status.....	11
Channel and Redundant Channel Status	12
<i>Operation</i>	<i>12</i>
Global Disable	12
System Reset	13
System Status LEDs	13
Ethernet Status LEDs	13
<i>Maintenance</i>	<i>13</i>
GUDA Device Administrator Options	14
Save Configuration Locally	14
Import Saved Configuration	15

GUDA Software Updates	15
Troubleshooting	15
Service and Spare Parts.....	16
<i>Specifications</i>	<i>16</i>
Electrical.....	16
Ethernet	16
Mechanical.....	16
Environmental.....	16
Audio	16



GAI-TRONICS®
A HUBBELL COMPANY

Model 370-901 SP2 to Page/Party® Bridge

Confidentiality Notice

This manual is provided solely as an installation, operation, and maintenance guide and contains sensitive business and technical information that is confidential and proprietary to GAI-TRONICS. GAI-TRONICS retains all intellectual property and other rights in or to the information contained herein, and such information may only be used in connection with the operation of your GAI-TRONICS product or system. This manual may not be disclosed in any form, in whole or in part, directly or indirectly, to any third party.

General Information

The Model 370-901 SP2 to Page/Party® Bridge interfaces GAI-TRONICS SP2 stations to existing Page/Party® systems. The bridge is capable of integrating completely into a Page/Party® or ICS system. Audio detection and isolate functionality ensures proper operation of existing Page/Party® accessories.

Features

- converts six 33-ohm audio lines to SP2 multicast channels (one page line and five party lines)
- indoor, wall-mount unit
- six channel isolation inputs
- configurable system isolation functionality
- six contact outputs

Option

SP2 to Page/Party® Redundancy

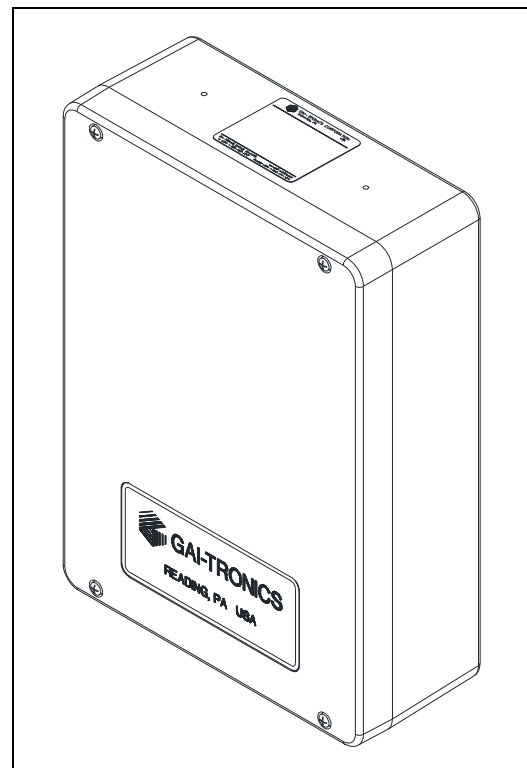

Figure 1. SP2 to Page/Party® Bridge

Installation

Important Safety Instructions

- **Read, follow, and retain instructions**—All safety and operating instructions should be read and followed before operating the unit. Retain instructions for future reference.
- **Heed warnings**—Adhere to all warnings on the unit and in the operating instructions.
- **Attachments**—Attachments not recommended by the product manufacturer should not be used; as they may cause hazards.

Open the Enclosure

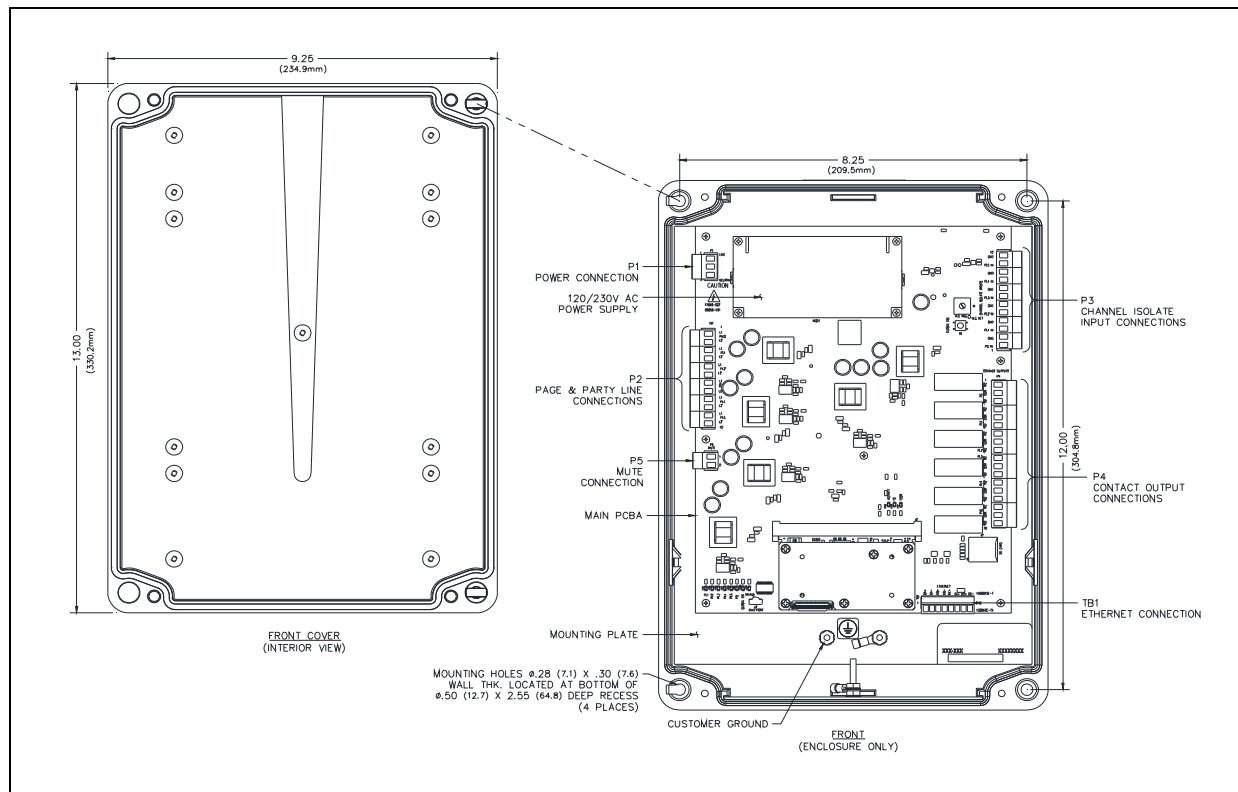

Figure 2. Model 370-901 SP2 to Page/Party® Bridge

1. Remove and retain the four screws on the front cover.
2. Open the hinged front cover of the enclosure and turn it to the left.



Warning: Observe precautions for handling electrostatic sensitive devices.

3. Pull up on the left side of the enclosure front cover until the hinge pins pull loose.
4. Separate the front and rear sections.
5. Set the front cover of the enclosure and the four screws aside.

Mount the Enclosure

1. Determine the conduit or cable gland location(s) on the rear enclosure (see [Figure 3](#)).

NOTE: The drill spots provided on the outside of the enclosure do not line up with the center of the holes that must be drilled in the enclosure to accept the conduit.

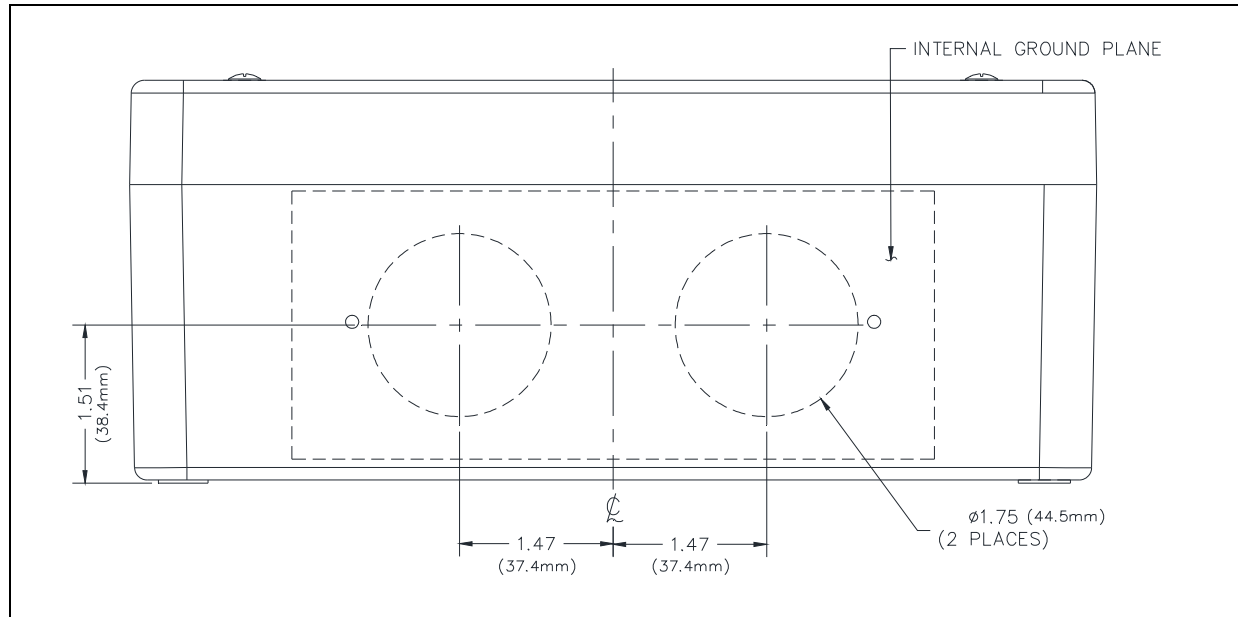

Figure 3. Ground Plate Hole Locations

2. Cut or punch the appropriate size hole(s) in the enclosure.
The ground plate accepts two conduits up to 1.75 inches in diameter.
3. Secure the rear enclosure to the wall with screws or appropriate fasteners.
The enclosure mounting holes are 0.280-inches in diameter.
4. Install conduit using Myers™ ST-4 (1.25-inch) Scru-Tite® hubs or equivalent.
Reducers must be used for smaller conduit sizes to ensure proper contact with the supplied grounding plates. Hub(s) must be connected to the conduit before being connected to the enclosure.

Field Terminations

The SP2 to Page/Party® Bridge provides terminal blocks on the main PCBA located in the rear of the enclosure for field wiring the power, 33-ohm Page/Party® audio lines, Ethernet, channel isolation inputs, and contact outputs (see [Figure 4](#))

Earth Ground

The bridge must be connected to earth ground.

1. Pull the power supply cable or a separate green/yellow sheathed ground cable into the enclosure.
2. Install a #6 ring lug on the ground conductor.
3. Secure the ground conductor to the CUSTOMER GROUND lug located in the bottom of the rear enclosure (see [Figure 2](#)).

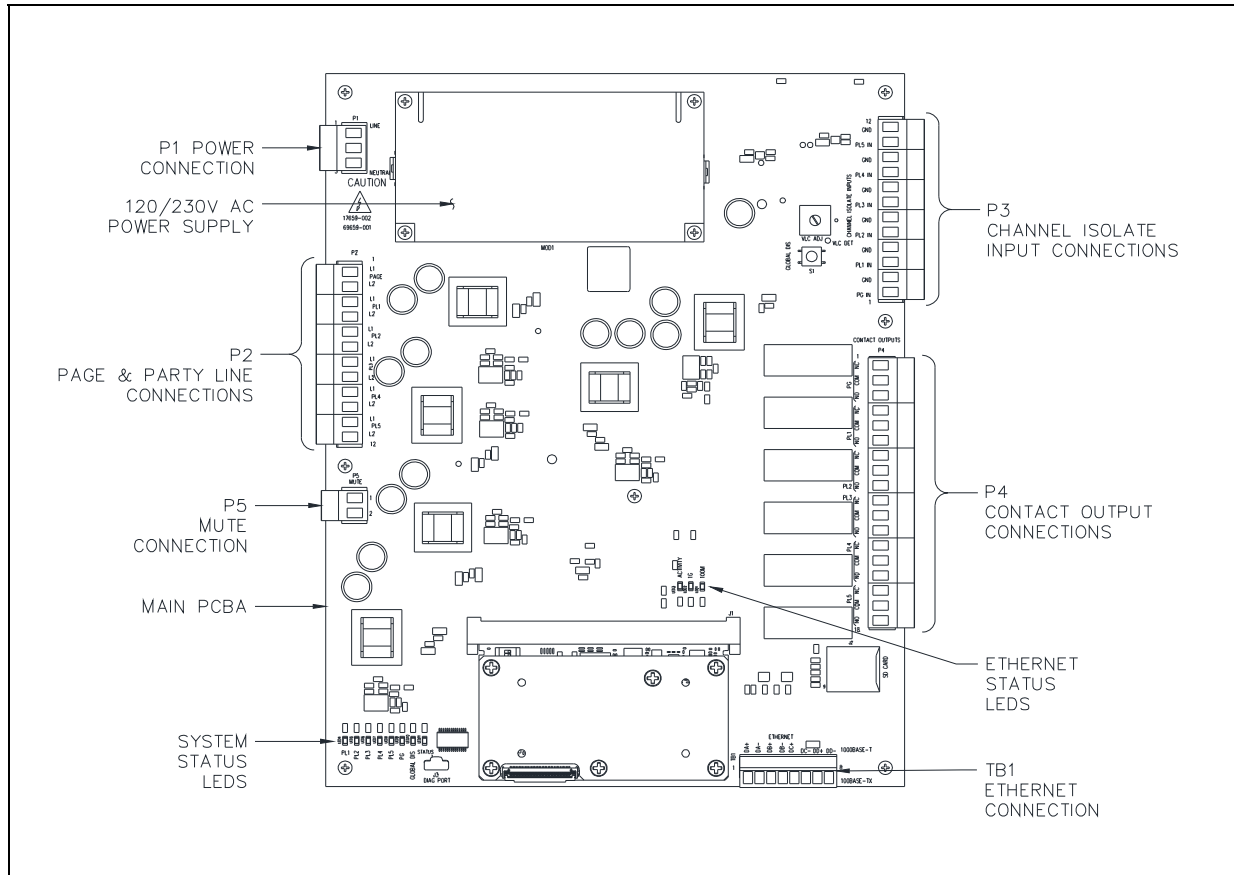

Figure 4. Main PCBA

Ethernet—TB1

Terminate the Ethernet connection at terminal block TB1.

1. Pull a Category 5 or better Ethernet cable through the conduit and into the enclosure.
2. Install ferrules onto the wire ends.
3. Connect the Ethernet cable to the 8-position pluggable terminal block TB1 (see [Figure 4](#) and [Table 1](#)).
4. Connect the pluggable terminal block to terminal block receptacle TB1.

Table 1. Ethernet Connector Wiring—TB1

1000Base-T Signal (Label)	100Base-TX Signal (Label)	Wire Color	Wire Color Designator
DA+	TX+	Orange Stripe	o
DA-	TX-	Solid Orange	O
DB+	RX+	Green Stripe	g
DB-	RX-	Solid Green	G
DC+		Solid Blue	B
DC-		Blue Stripe	b
DD+		Brown Stripe	br
DD-		Solid Brown	BR

Page/Party® 33-Ohm Audio Connections—P2

Table 2. Page and Party Line 33-Ohm Audio Connections—P2

Terminal block P2 provides connections for six, 33-ohm audio lines (typically one page and five party lines). Connect the six Page/Party® audio lines to the six, two-position pluggable terminal blocks P2 as follows:

1. Pull the Page/Party® system cable through the conduit and into the enclosure.
2. Install ferrules onto the wire ends of each page and party line audio pair.
3. Connect each audio pair to one of the two-position terminal blocks (see [Figure 4](#) and [Table 2](#)).
4. Connect the six P2 terminal blocks to the terminal block receptacle P2 (see [Figure 4](#)).

Terminal	Label	Wire Size/Color
P2-1	PAGE	L1
P2-2		L2
P2-3	PL1	L1
P2-4		L2
P2-5	PL2	L1
P2-6		L2
P2-7	PL3	L1
P2-8		L2
P2-9	PL4	L1
P2-10		L2
P2-11	PL5	L1
P2-12		L2

See the [60029 Series System Cable](#) section below

PLn := Party Line 1..5

60029 Series Page/Party® System Cable

Page/Party® stations should be connected using GAI-TRONICS 60029 Series system cable. Refer to [Table 3](#) for the Page/Party® system cable color codes:

Table 3. Page/Party® 60029 Series System Cable

16-Conductor Cable (60029 Series)		16-Conductor Cable (60029 Series)	
Color Code	Function	Color Code	Function
Black	120 V ac Line	Tan/Violet	Party Line 2 (L2)
White	120 V ac Neutral	Blue	Party Line 3 (L1)
Green/Yellow	Ground	Tan/Blue	Party Line 3 (L2)
Red/Blue	Page Line (L1)	Brown	Party Line 4 (L1)
Blue/Red	Page Line (L2)	Tan/Brown	Party Line 4 (L2)
Red	Party Line 1 (L1)	Yellow	Party Line 5 (L1)
Tan/Red	Party Line 1 (L2)	Tan/Yellow	Party Line 5 (L2)
Violet	Party Line 2 (L1)	Orange	Spare

Channel Isolation Inputs—P3

Channel isolation inputs independently isolate SP2 multicast channel audio from each of the six Page/Party® audio lines. Activation of an input disconnects the SP2 and Page/Party® audio signals in the bridge for that audio channel. This prevents audio from traversing the bridge to the receiving system.

Terminate the six channel isolation inputs to terminal block P3 (see [Figure 4](#)). P3 is a 12-position terminal block. Six, two-position terminal plugs are used; one for each channel isolation input. Complete the termination as follows:

1. Pull the cable(s) for the channel isolation inputs through the conduit and into the enclosure.
2. Install ferrules onto the wire ends.
3. Connect each channel pair to the two-position pluggable terminal block for that channel (see [Figure 4](#) and [Table 4](#)).
4. Plug the six two-position pluggable blocks into terminal block P3.

Table 4. Channel Isolation Input Connections—P3

Channel Isolated	Label	Description
Page Line	PG IN	Page In +
	GND	Page In –
Party Line 1	PL1 IN	Party Line 1 +
	GND	Party Line 1 –
Party Line 2	PL2 IN	Party Line 2 +
	GND	Party Line 2 –
Party Line 3	PL3 IN	Party Line 3 +
	GND	Party Line 3 –
Party Line 4	PL4 IN	Party Line 4 +
	GND	Party Line 4 –
Party Line 5	PL5 IN	Party Line 5 +
	GND	Party Line 5 –

Contact Outputs—P4

The SP2 to Page/Party® Bridge is equipped with six contact outputs (see [Figure 4](#)). Outputs become active when a digital audio signal is detected on the associated SP2 audio channel. These outputs may then be used to actuate field devices when SP2 page or party-lines go off-hook.

The outputs are terminated at terminal block P4. P4 is an 18 position terminal block. Three-position pluggable terminal blocks are used for each output to simplify the connection of the outputs:

1. Pull the cable(s) for the contact outputs through the conduit and into the enclosure.
2. Install ferrules onto the wire ends.
3. Connect each set of output contact wires to the appropriate three position pluggable terminal block (see [Figure 4](#) and [Table 5](#)).
4. Connect each three-position pluggable terminal block to terminal block P4.

Table 5. Contact Outputs—P4

Output	Label	Description
Page Line	NC	normally closed page contact
	COM	page output common
	NO	normally open page contact
Party Line 1	NC	normally closed PL1 contact
	COM	PL1 output common
	NO	normally open PL1 contact
Party Line 2	NC	normally closed PL2 contact
	COM	PL2 output common
	NO	normally open PL2 contact
Party Line 3	NC	normally closed PL3 contact
	COM	PL3 output common
	NO	normally open PL3 contact
Party Line 4	NC	normally closed PL4 contact
	COM	PL4 output common
	NO	normally open PL4 contact
Party Line 5	NC	normally closed PL5 contact
	COM	PL5 output common
	NO	normally open PL5 contact

PL_n := Party Line 1..5

Mute Connection—P5

The muting conductor of the Page/Party® system cable has no function in the SP2 to Page/Party® Bridge. Terminal block P5 provides a dead ended termination for the muting conductor of the Page/Party® system cable (see [Figure 4](#)):

1. Install a ferrule onto the end of the orange wire.
2. Connect the wire to pin one on pluggable terminal block P5.
3. Connect the pluggable terminal block to terminal block P5.

Power—P1

The SP2/Page/Party® Bridge operates from a 120/230 V ac, 50/60 Hz power source. AC power is connected at terminal block P1:

1. Pull the cable from the power source into the enclosure.
2. Install ferrules onto the wire ends.
3. Connect the line, and neutral, conductors to the pluggable terminal block (see [Figure 4](#) and [Table 6](#)).
4. Connect the pluggable terminal block to terminal block P1

Table 6. AC Power—P1

Pin	Label	Description
P1-1	LINE	ac hot
P1-2		no connection
P1-3	NEUTRAL	neutral

Close the Enclosure

1. Reconnect the front cover to the rear enclosure by pushing the hinge pins on the front cover into the holes on the left side of the rear enclosure until a click is heard.
2. Rotate the front cover to close the enclosure.
3. Install and tighten the four screws on the front cover.

Configuration

SP2 to Page/Party® Bridges are configured using the GUDA (GAI-TRONICS Universal Device Application) software. Install the GUDA software and run it to configure Page/Party® bridges as follows:

1. Launch the GUDA application by double clicking the GAI-TRONICS Universal Device Application shortcut from the start menu.

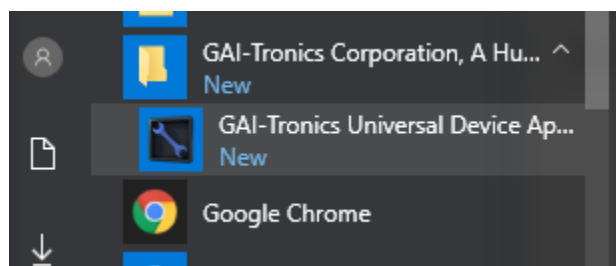

2. Choose the network interface to perform the discovery.

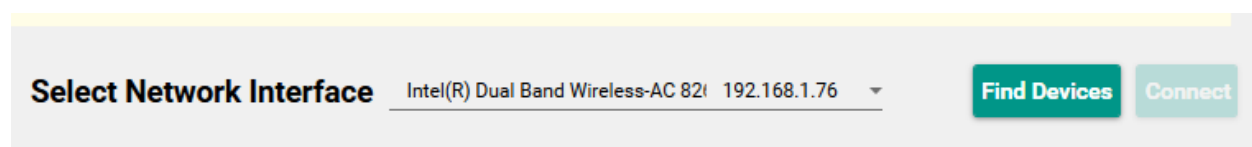

- Click the FIND DEVICES button to perform a device discovery from the GUDA screen:

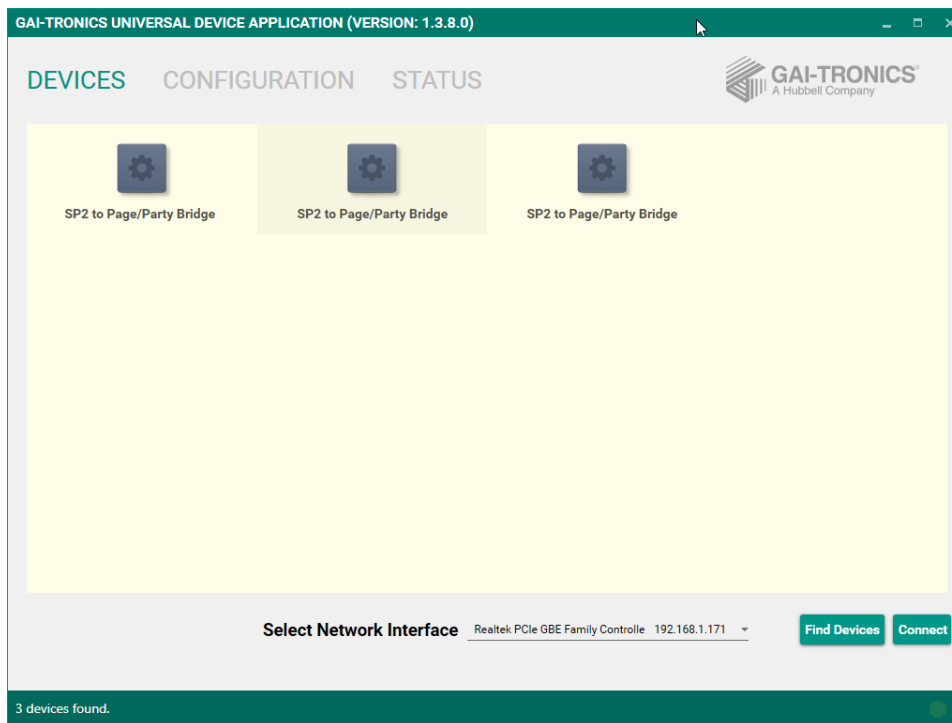

- Double click the SP2 TO PAGE/PARTY® BRIDGE to configure, from the list of devices displayed:
Bridges that are not configured appear as follows:



- Enter the default user name (shown) and password (**pageparty**) in the DEVICE LOGIN box, then click LOGIN:

Device Login

SP2 to Page/Party Bridge

User Name:

Password:

Cancel

LOGIN

- Change the password on first login.

This is required on the initial connection. The password can be changed at a future time from the admin screen.

Interface Configuration

The CONFIGURATION screen appears with the INTERFACE properties shown:

The screenshot shows the 'CONFIGURATION' tab of the GAI-TRONICS UNIVERSAL DEVICE APPLICATION. On the left, a tree view shows 'Interface' expanded to 'Channels', with 'Channel 1' through 'Channel 6' listed. The main area is titled 'Interface' and contains the following configuration fields:

- Interface Name: SP2 to Page/Party Bridge
- Address Mode: Static, DHCP
- Control TTL: 5 (with +/- controls)
- Control Port: 64020 (with +/- controls)
- IP Address: 192.168.1.6
- Netmask: 255.255.255.0
- Default Gateway: 0.0.0.0
- Primary DNS: 0.0.0.0
- Secondary DNS: 0.0.0.0
- NTP Server: 0.0.0.0
- Allow HW Disable: Yes (dropdown menu)
- Interface Mode: Standalone (dropdown menu)
- Redundancy ID: (empty field)

At the bottom right, there are buttons for LOGOUT, ADMIN, and UPDATE. At the bottom left, there are icons for save and refresh. A status bar at the very bottom indicates 'Connected to SP2 to Page/Party Bridge'.

Configure the following properties for the bridge's NIC:

- **Interface Name**—name for the SP2 to Page/Party® Bridge
- **Address Mode**—select Static or DHCP
- **Control TTL**—time to live for control packets
- **Control Port**—memory address of the control service
- **IP Address**—client network address, leave blank for DHCP clients
- **Netmask**—subnet mask, leave blank for DHCP clients
- **Default Gateway**—IP address of router to other networks, leave blank for DHCP clients
- **Primary DNS**—primary DNS server, leave blank for DHCP clients
- **Secondary DNS**—secondary DNS server, leave blank for DHCP clients
- **NTP Server**—network time protocol server IP address, leave blank for DHCP clients
- **Allow HW Disable**—**Yes** or **No**
- **Interface Mode**—**Standalone**, **Primary**, or **Backup**
- **Redundancy ID**—unique name for redundant bridges—must be identical on the primary and secondary bridges configured for redundancy

Channel Configuration

Click on each channel and configure the properties below. Click the UPDATE button in the lower right corner to confirm and commit the changes.

GAI-TRONICS UNIVERSAL DEVICE APPLICATION (VERSION: 1.3.9.0)

DEVICES CONFIGURATION STATUS

GAI-TRONICS
A Hubbell Company

Interface

Channels

Channel 1

Channel 2

Channel 3

Channel 4

Channel 5

Channel 6

Channel 1

Channel Name Page

Enabled Yes

Multicast Group 239.1.1.1

Multicast Port 50002

Multicast TTL 8

Analog VOX Threshold (mV) 5

Analog Output Level 0

Digital Output Level 0

VLC Enabled No

Digital VLC Level 0

Invert Off-hook Contact No

Isolate Input Enable Yes

Invert Isolate Input No

Channel Direction Bi-Directional

Full Duplex No

LOGOUT ADMIN UPDATE

Connected to SP2 to Page/Party Bridge

- **Channel Name**—name for the connected audio channel
- **Enabled**—**Yes** or **No**
- **Multicast Group**— multicast IP address for the audio channel
- **Multicast Port**—multicast service port address for the audio channel
- **Multicast TTL**—time to live for multicast network traffic
- **Analog VOX Threshold (mV)**—signal voltage where the VOX circuit picks up (1–100 mV).
- **Analog Output Level**—–12 to 12 dB gain
- **Digital Output Level**—–12 to 12 dB gain
- **VLC Enabled**—**Yes** or **No**
- **Digital VLC Level**—volume level for VLC controlled audio
- **Invert Off-hook Contact**—**Yes** or **No**
- **Isolate Input Enable**—**Yes** or **No**
- **Invert Isolate Input**—**Yes** or **No**
- **Channel Direction**—Bi-Directional, Digital to Analog, Analog to Digital, or ISOLATED.
- **Full Duplex**—Yes or No, for single or bi-directional audio. Set to **No** for page line audio channels.

GUDA Status

Click on the **STATUS** tab on the main GUDA screen to obtain status for the bridge or redundant bridge configuration.

Interface Status

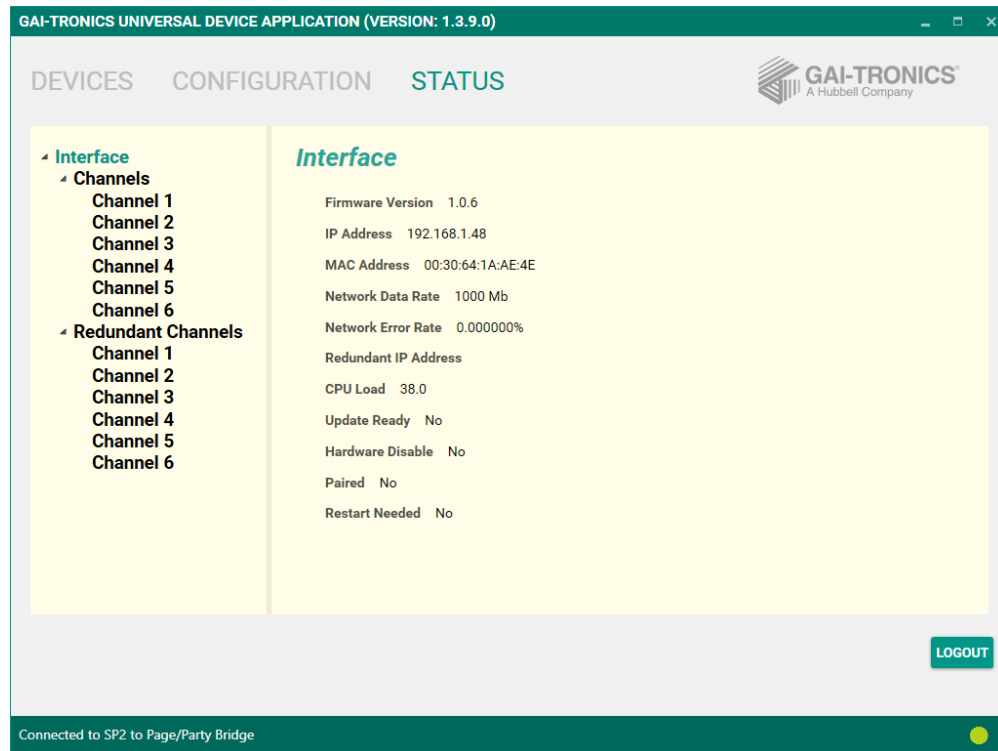

The INTERFACE STATUS screen provides the following information:

- **Firmware Version**—bridge firmware version
- **IP Address**—IP address currently assigned to the bridge
- **MAC Address**—MAC address of the bridge
- **Network Data Rate**—bandwidth of the bridge’s Ethernet link
- **Network Error Rate**—percent of errors in network packets
- **Redundant IP Address**—IP address of the redundant bridge (when configured in redundancy mode)
- **CPU Load**—current load on the CPU in percent
- **Hardware Disable**—**Yes** or **No**
- **Paired**—**Yes** or **No**
- **Restart Needed**—**Yes** or **No**

Channel and Redundant Channel Status

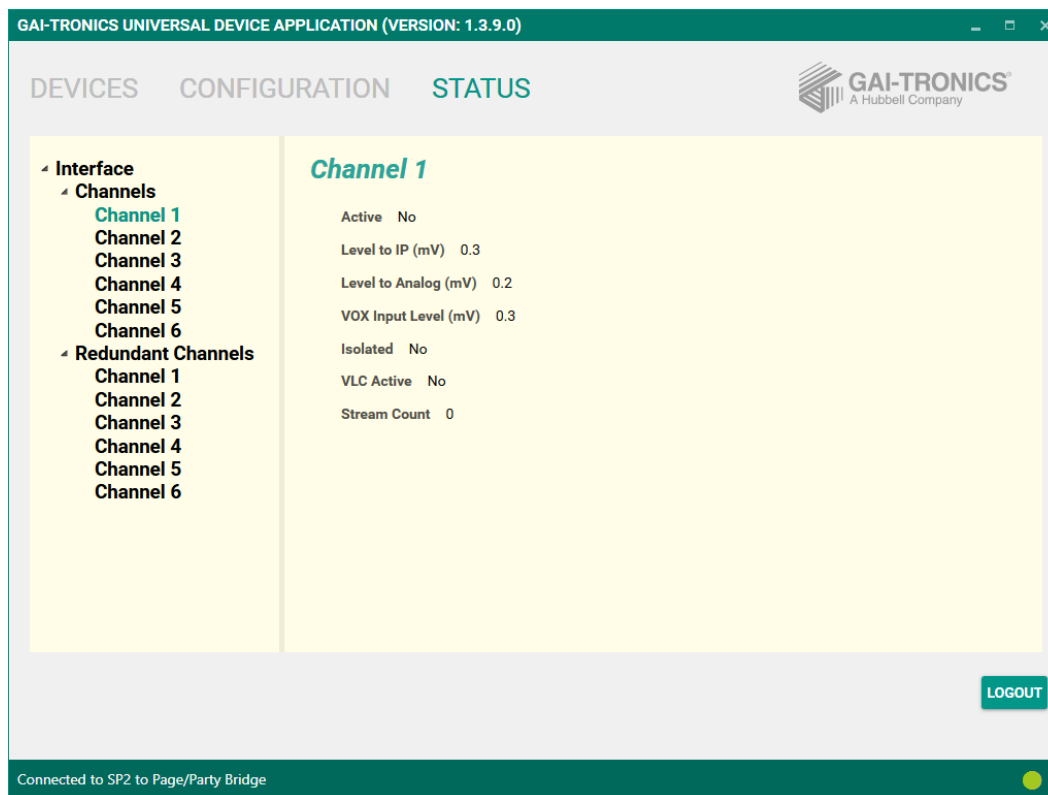

The CHANNEL STATUS and REDUNDANT CHANNEL STATUS screens provide the following information for each channel:

- **Active**—YES or NO
- **Level to IP (mV)**—audio signal level to SP2 system in millivolts
- **Level to Analog (mV)**—signal level to Page/Party® system in millivolts
- **VOX Input Level (mV)**—signal level for voice activation in millivolts
- **Isolated**—YES or NO
- **VLC Active**—YES or NO
- **Stream Count**—number of simultaneous audio streams passing through the bridge

Operation

The SP2 to Page/Party® Bridge provides real-time audio communication between SP2 and Page/Party® systems. No user interaction is required after the bridge is installed and configured. The bridge is equipped with eight status LEDs to provide indication of the bridge's operation. A global disable button is also provided to completely isolate the connected SP2 and Page/Party® systems.

Global Disable

Press and release the GLOBAL DIS press-button switch (**S1**) to completely isolate the SP2 and Page/Party® systems from each other. The switch operates as a toggle. Press the button to isolate the two systems. Press the button again to enable bridging the two systems. The switch state is logically tied to the setting configured in the GUDA software.

System Reset

Hold the GLOBAL DIS press-button switch (**S1**) on the main PCBA for 8 seconds to reset the SP2 to Page/Party® Bridge to factory default settings.

System Status LEDs

Eight status LEDs are located in the lower left corner on the main PCBA (see [Figure 4](#)). The status LEDs provide indication that audio is present on each of the six audio lines, the state of the global disable feature, and PCBA board status. All eight status LEDs are red. The audio line detection LEDs turn on immediately when an audio channel on the Page/Party® system is active. The LEDs do not turn off instantly when the audio channel is closed; a VOX circuit keeps the channel open to ensure that the channels are not disconnected with a pause in conversation.

Table 7. System Status LEDs

LED	State	Description
PL1	On	activity on party line one
PL2	On	activity on party line two
PL3	On	activity on party line three
PL4	On	activity on party line four
PL5	On	activity on party line five
PG	On	activity on page line
GLOBAL DIS	On	bridge is disabled
STATUS	Blinking	heartbeat LED blinks every five seconds

Ethernet Status LEDs

The bridge is equipped with three Ethernet status LEDs (see [Figure 4](#) and [Table 8](#)).

Table 8. Ethernet Status LED Indication

LED	Color	State	Description
ACTIVITY	yellow	blinking	Ethernet network status—The bridge is sending and/or receiving packets on the Ethernet network.
1G	green	On	1000 Mb connection link
100M	green	On	100 Mb Ethernet link

Maintenance

The SP2 to Page/Party® Bridge contains no user serviceable parts. There are no adjustments necessary after the device is configured using the GUDA application. There are several options in the ADMIN box of the GUDA application for maintenance of the bridge.

GUDA Device Administrator Options

The following options are available after clicking the ADMIN button located in the lower right corner of the GUDA configuration screen area:

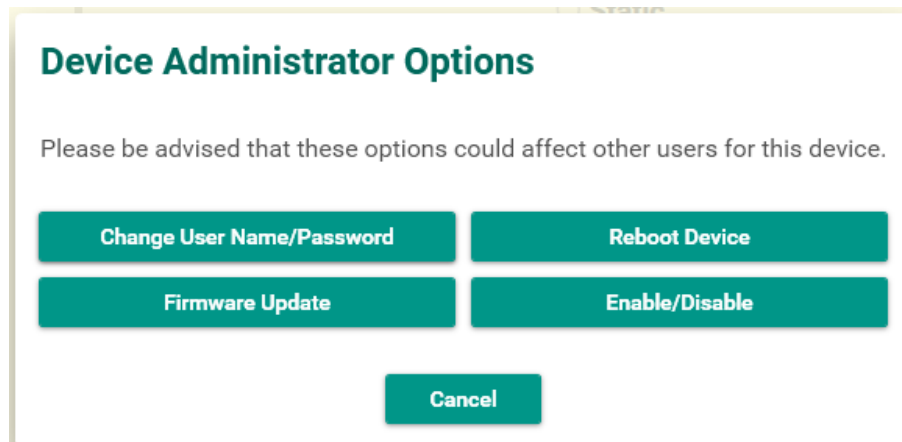

- **Change User Name/Password**—set a new user name and/or password.
- **Reboot Device**—reboots the SP2 to Page/Party® Bridge.
- **Firmware Update**—opens the following box:

Device Firmware Update

Select the firmware update file for the connected device to use and select BEGIN UPDATE to transfer the file.

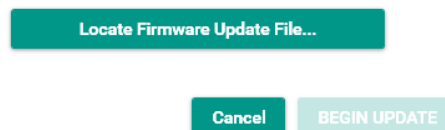

Click the LOCATE FIRMWARE UPDATE FILE... button to open a standard Windows® OPEN dialog box. Browse to the desired folder and open the desired firmware file, and then click BEGIN UPDATE in the DEVICE FIRMWARE UPDATE box to update the devices firmware.

- **Enable/Disable**—toggles the isolation of all SP2 and Page/Party® audio channels. This toggle is logically tied to the enable/disable GLOBAL DIS press-button switch (S1), located on the main PCBA.
- **Cancel**—close the box and return to the main screen of the GUDA.

Save Configuration Locally



Click the SAVE CONFIGURATION LOCALLY button to save a copy of the bridge configuration on a local disk drive.

NOTE: Only designated values that are not device specific are saved.

A standard Windows® SAVE AS dialog box opens. Save the file in the desired location.

Import Saved Configuration



Click the IMPORT SAVED CONFIGURATION button to load a saved configuration to the bridge.

NOTE: Only designated values that are not device specific are imported.

A standard Windows® OPEN dialog box opens. Browse to the desired folder and open the desired configuration file. Click the UPDATE button for the imported configuration to take effect.

GUDA Software Updates

Click OK to install updates to the GUDA software when the UPDATE AVAILABLE box appears after launching the GUDA application. Updates are made available for automatic download and installation upon launching the GUDA.

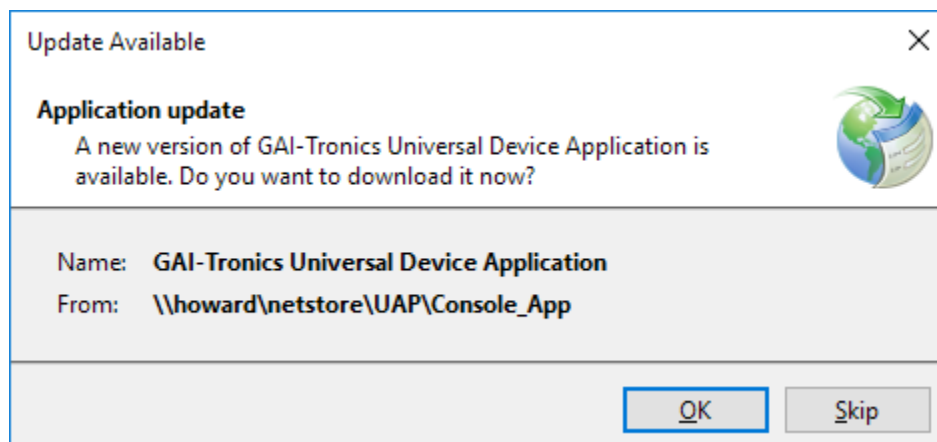

Troubleshooting

Problem	Solution
Any problem with station performance	Always review all steps of installation, ensuring that you correctly followed all steps. Check all terminations on the board and in the Line Balance Assembly before proceeding to any other adjustments.
Crosstalk	One or more system cable pairs may be improperly terminated. Visually inspect the system cable for accidental crossing of cable pairs or grounds.

Service and Spare Parts

If the equipment requires service or spare parts, contact your Regional Service Center for assistance. If service is required, a return authorization number (RA#) will be issued. Equipment should be shipped prepaid to GAI-TRONICS with a return authorization number and a purchase order number. If the equipment is under warranty, repairs or a replacement will be made in accordance with GAI-TRONICS' warranty policy. Please include a written explanation of all defects to assist our technicians in their troubleshooting efforts. Call 800-492-1212 inside the USA or 610-777-1374 outside the USA for help with identifying the Regional Service Center closest to you.

Table 9. Spare Parts

Model Number	Description
69659-001	PCBA, SP2 to Page/Party® Interface
40404-105	replacement ac power supply

Specifications

Electrical

Supply voltage 120/230 V ac
 Input frequency range 50/60 Hz
 Ethernet 100Base-TX/1000Base-T with IGMP
 Output relay contact rating..... 1 A @ 30 V dc
 Channel isolation inputs..... dry contact

Ethernet

Cable Category 5 or better
 Speed..... 100 Mbps (minimum)
 Maximum stations..... 4096

Mechanical

Construction..... high-impact glass reinforced polyester, gray
 Dimensions 13.0 H × 9.25 W × 4.00 D in (330 × 325 × 102 mm)
 Mounting..... wall mount, four 0.28 in holes

Environmental

Temperature range +32 °F to +122 °F (0 °C to +50 °C)
 Relative humidity..... 95%, non-condensing

Audio

Frequency response..... 250–3,000 Hz, +0/–3 dB ref. to 1 kHz
 Distortion <1.5% THD @ 1 kHz

FCC & ICES Information: This equipment has been tested and found to comply with the limits for a Class A digital device, pursuant to part 15 of the FCC Rules. These limits are designed to provide reasonable protection against harmful interference when the equipment is operated in a commercial environment. This equipment generates, uses, and can radiate radio frequency energy and, if not installed and used in accordance with the instruction manual, may cause harmful interference to radio communications. Operation of this equipment in a residential area is likely to cause harmful interference in which case the user will be required to correct the interference at their own expense.

Warranty

Equipment. GAI-Tronics warrants for a period of one (1) year from the date of shipment, that any GAI-Tronics equipment supplied hereunder shall be free of defects in material and workmanship, shall comply with the then-current product specifications and product literature, and if applicable, shall be fit for the purpose specified in the agreed-upon quotation or proposal document. If (a) Seller's goods prove to be defective in workmanship and/or material under normal and proper usage, or unfit for the purpose specified and agreed upon, and (b) Buyer's claim is made within the warranty period set forth above, Buyer may return such goods to GAI-Tronics' nearest depot repair facility, freight prepaid, at which time they will be repaired or replaced, at Seller's option, without charge to Buyer. Repair or replacement shall be Buyer's sole and exclusive remedy. The warranty period on any repaired or replacement equipment shall be the greater of the ninety (90) day repair warranty or one (1) year from the date the original equipment was shipped. In no event shall GAI-Tronics warranty obligations with respect to equipment exceed 100% of the total cost of the equipment supplied hereunder. Buyer may also be entitled to the manufacturer's warranty on any third-party goods supplied by GAI-Tronics hereunder. The applicability of any such third-party warranty will be determined by GAI-Tronics.

Services. Any services GAI-Tronics provides hereunder, whether directly or through subcontractors, shall be performed in accordance with the standard of care with which such services are normally provided in the industry. If the services fail to meet the applicable industry standard, GAI-Tronics will re-perform such services at no cost to buyer to correct said deficiency to Company's satisfaction provided any and all issues are identified prior to the demobilization of the Contractor's personnel from the work site. Re-performance of services shall be Buyer's sole and exclusive remedy, and in no event shall GAI-Tronics warranty obligations with respect to services exceed 100% of the total cost of the services provided hereunder.

Warranty Periods. Every claim by Buyer alleging a defect in the goods and/or services provided hereunder shall be deemed waived unless such claim is made in writing within the applicable warranty periods as set forth above. Provided, however, that if the defect complained of is latent and not discoverable within the above warranty periods, every claim arising on account of such latent defect shall be deemed waived unless it is made in writing within a reasonable time after such latent defect is or should have been discovered by Buyer.

Limitations / Exclusions. The warranties herein shall not apply to, and GAI-Tronics shall not be responsible for, any damage to the goods or failure of the services supplied hereunder, to the extent caused by Buyer's neglect, failure to follow operational and maintenance procedures provided with the equipment, or the use of technicians not specifically authorized by GAI-Tronics to maintain or service the equipment. **THE WARRANTIES AND REMEDIES CONTAINED HEREIN ARE IN LIEU OF AND EXCLUDE ALL OTHER WARRANTIES AND REMEDIES, WHETHER EXPRESS OR IMPLIED BY OPERATION OF LAW OR OTHERWISE, INCLUDING ANY WARRANTIES OF MERCHANTABILITY OR FITNESS FOR A PARTICULAR PURPOSE.**

Return Policy

If the equipment requires service, contact your Regional Service Center for a return authorization number (RA#). Equipment should be shipped prepaid to GAI-Tronics with a return authorization number and a purchase order number. If the equipment is under warranty, repairs or a replacement will be made in accordance with the warranty policy set forth above. Please include a written explanation of all defects to assist our technicians in their troubleshooting efforts.

Call 800-492-1212 (inside the USA) or 610-777-1374 (outside the USA) for help identifying the Regional Service Center closest to you.